

Virus protection in classrooms and other indoors

A. Mayer, H. Burtscher, J. Czerwinski, Th. Lutz, J. Mayer, R. Mayer, B. Rothen-
Rutishauser, T. Rüggeberg, P. Specht, E. Weingartner

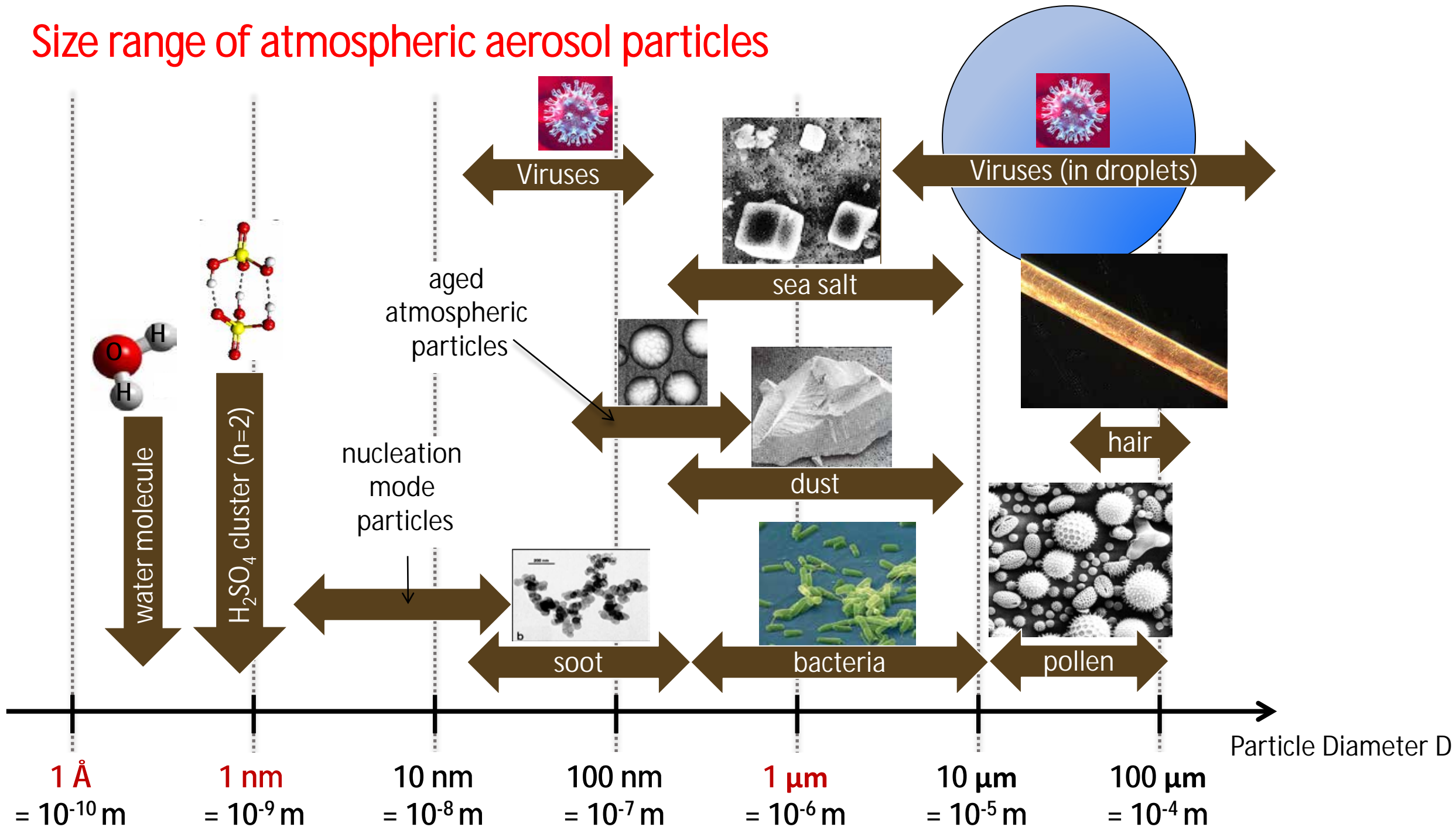

Size range of atmospheric aerosol particles





Tested Filters

Fibre-filters



several ceramic-filter

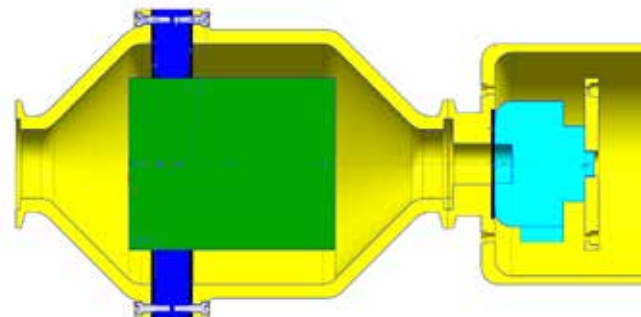
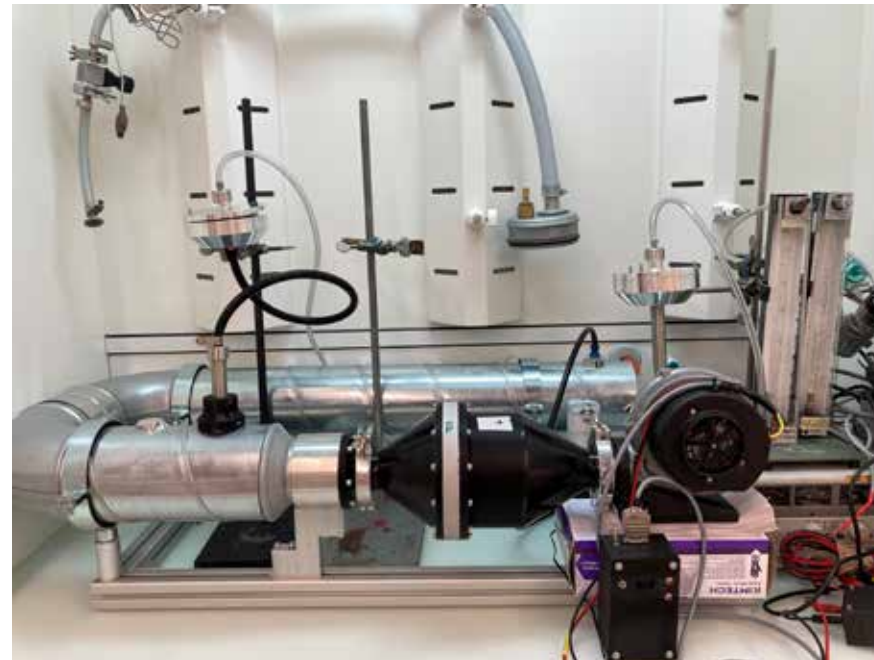

UV-devices

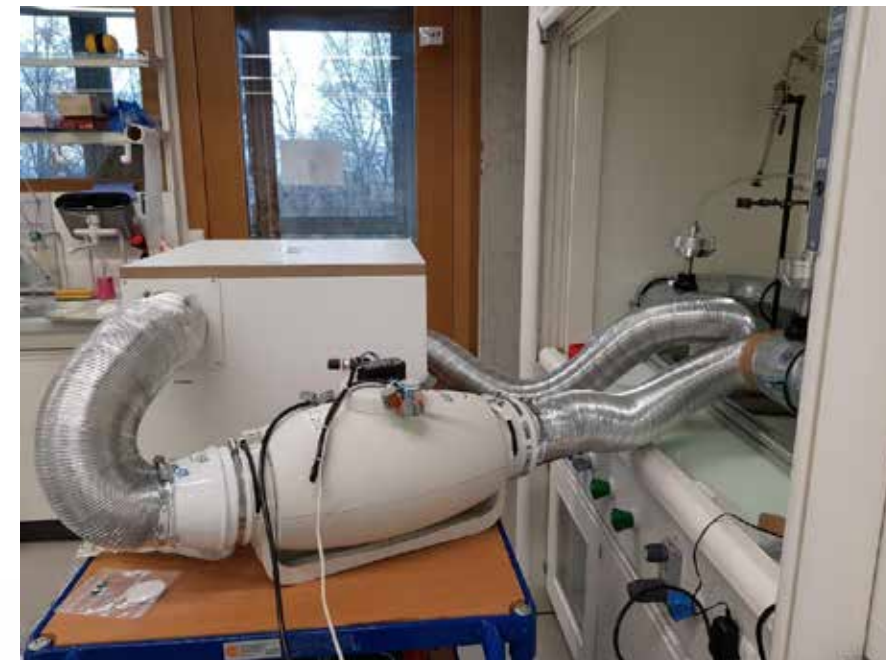



Results of filter-tests

- The filters behave the same for viruses as for aerosol particles
- Efficiencies up to almost 100% are achieved
- Pressure drop typically a few 100Pa

With existing filter technology, efficient cleaning is possible when particles/viruses reach the filter before they reach others

The ceramic wall flow filter



- High efficiency, filters with hierarchic pore structure also when new
- compact
- easy to clean
- can be heated
- mass product (GPF)





Approach:
vertical suction upwards

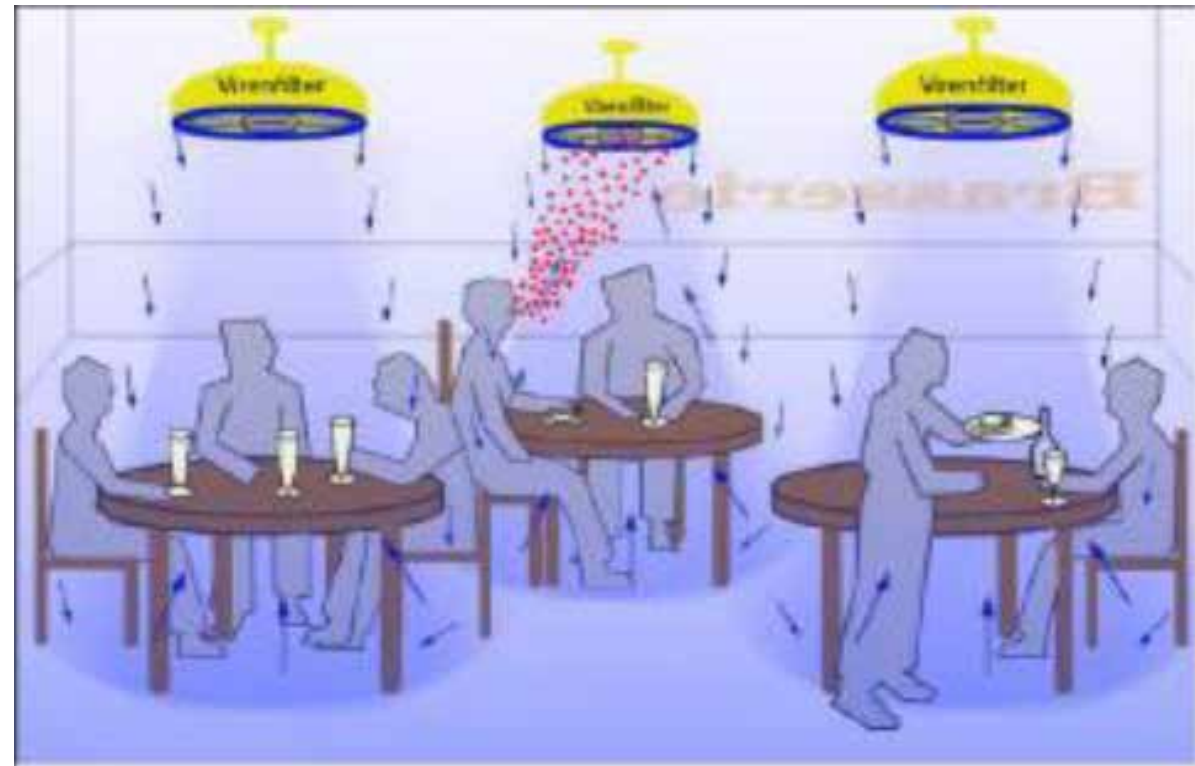

our approach in a classroom

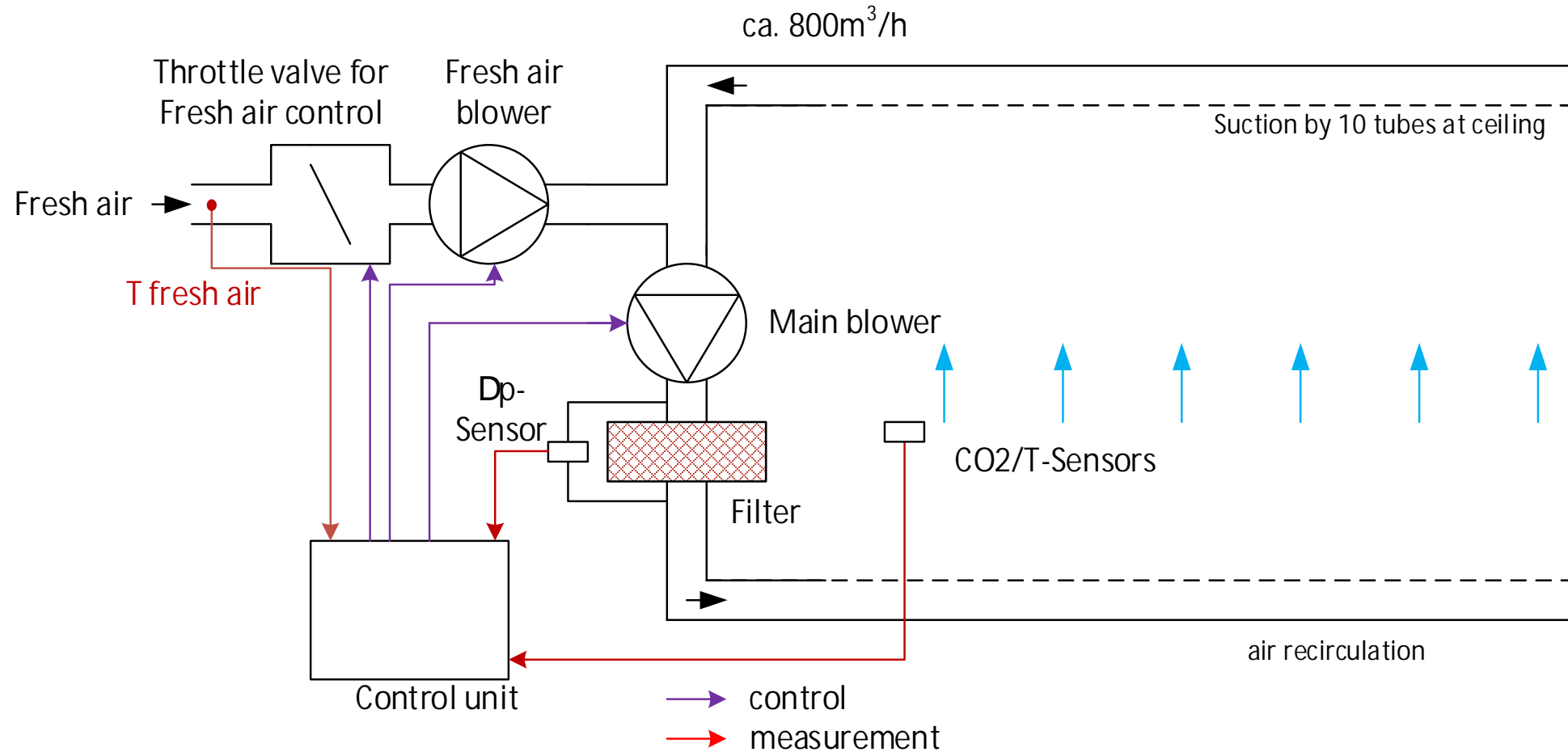



Ceiling suction with 10 fabric tubes

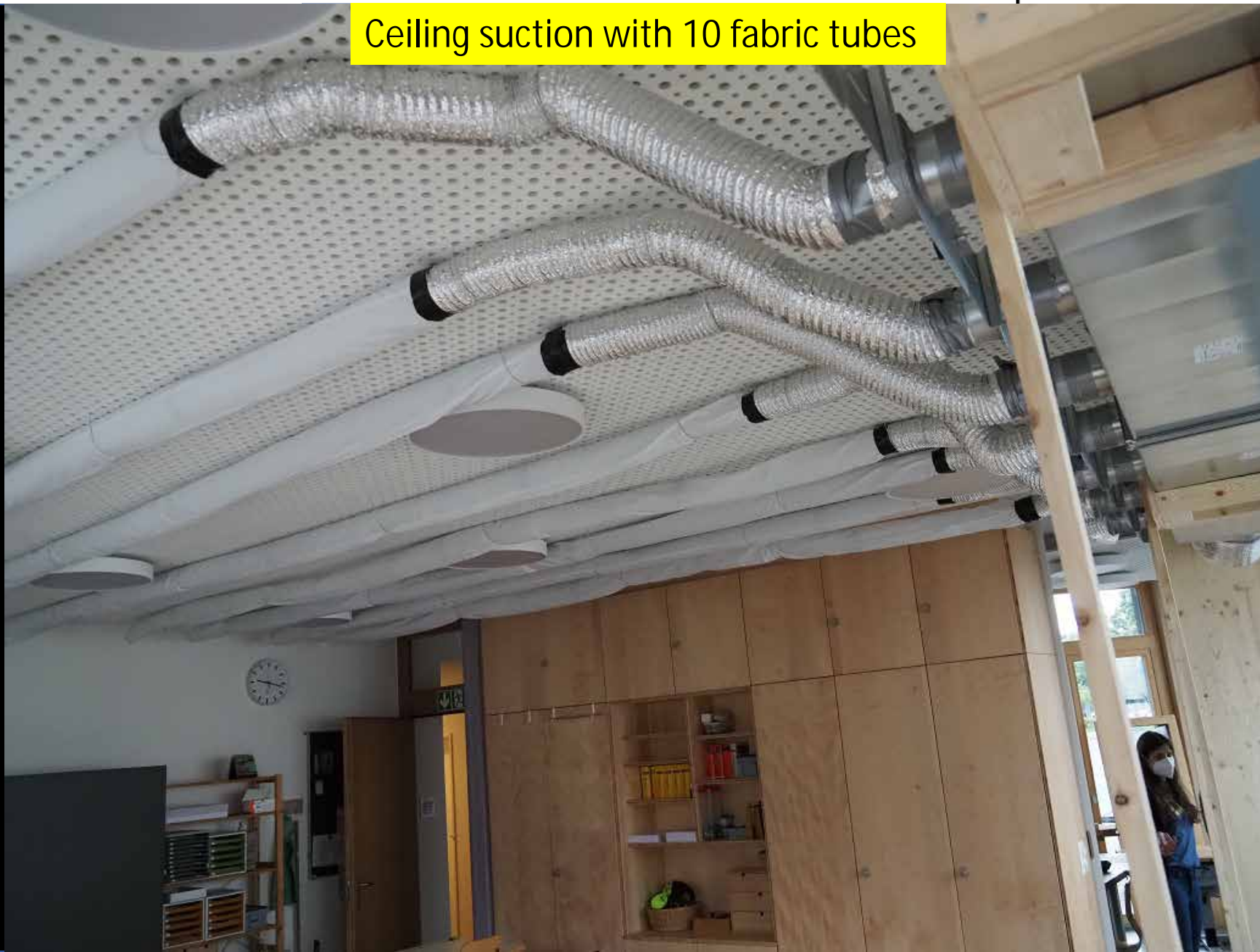

Blower, filter, control unit

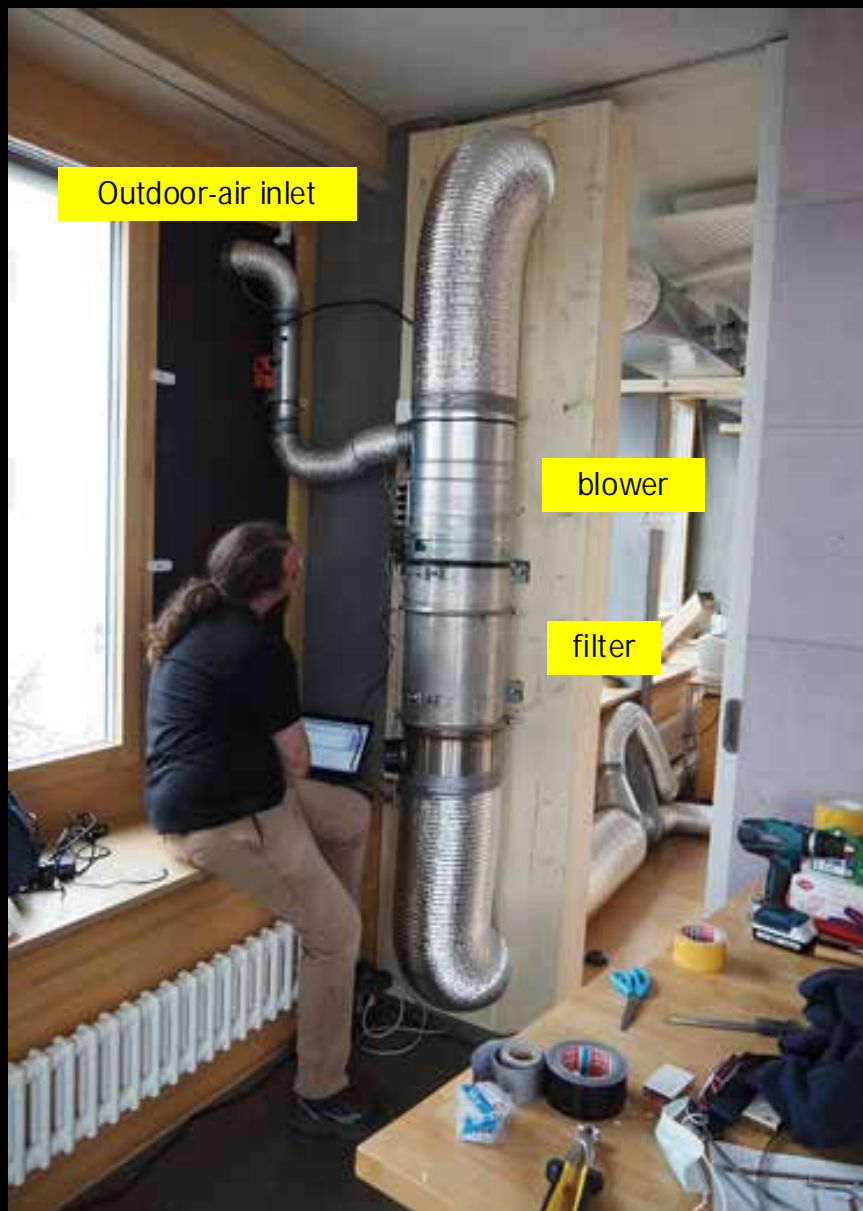

Flow recirculation by fabric-tubes

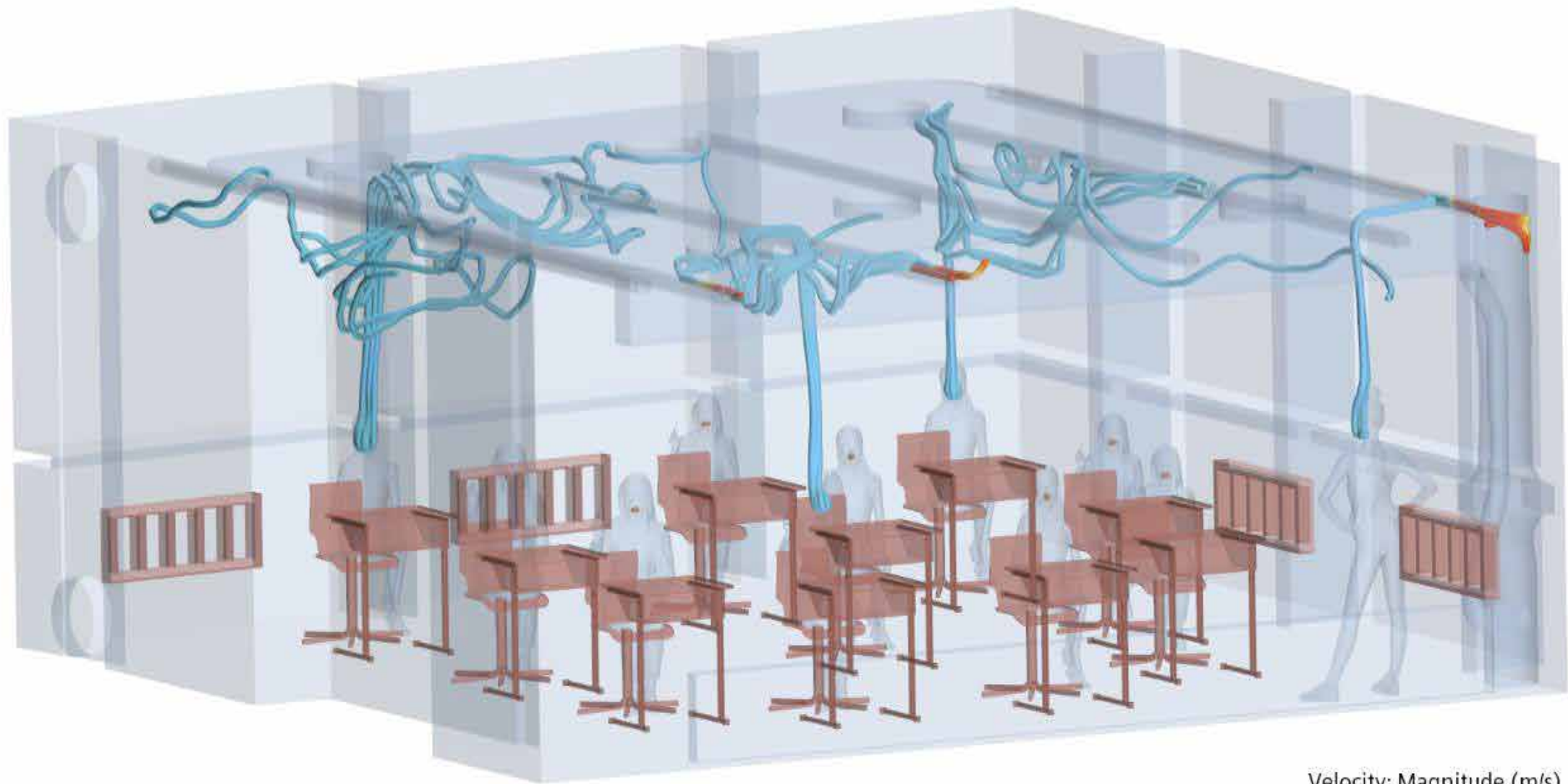



Zeitformen Wiederholung

- 1. Gegenwart (Präsens)
Bsp. Ich lese ein Buch.
- 2. Vergangenheit (Präteritum)
Bsp. Ich las ein Buch.
- 3. Abgeschlossene Vergangenheit (Perfekt)
Bsp. Ich habe ein Buch gelesen.
- 4. Unvergangenheit (Plusquamperfekt)
Bsp. Als meine Eltern nach Hause kamen, hatte ich das Buch schon gelesen.

Erkennzeichen

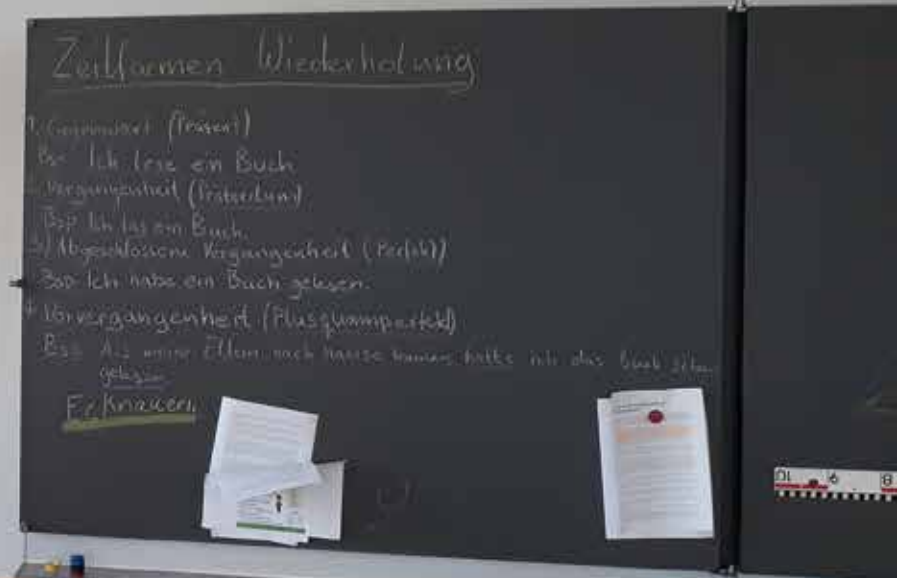



setup



Concentration as function of time

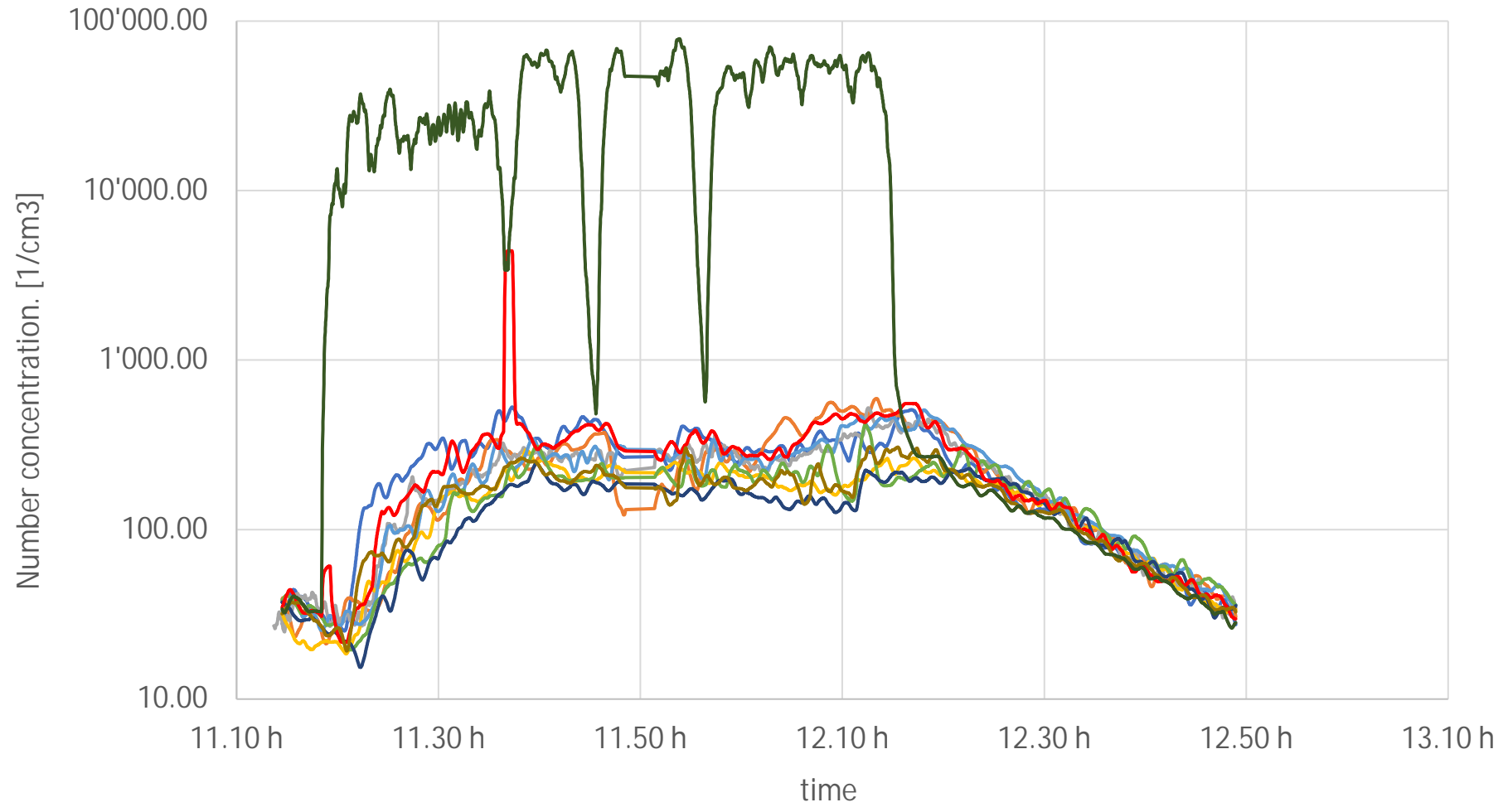

Mittelwerte

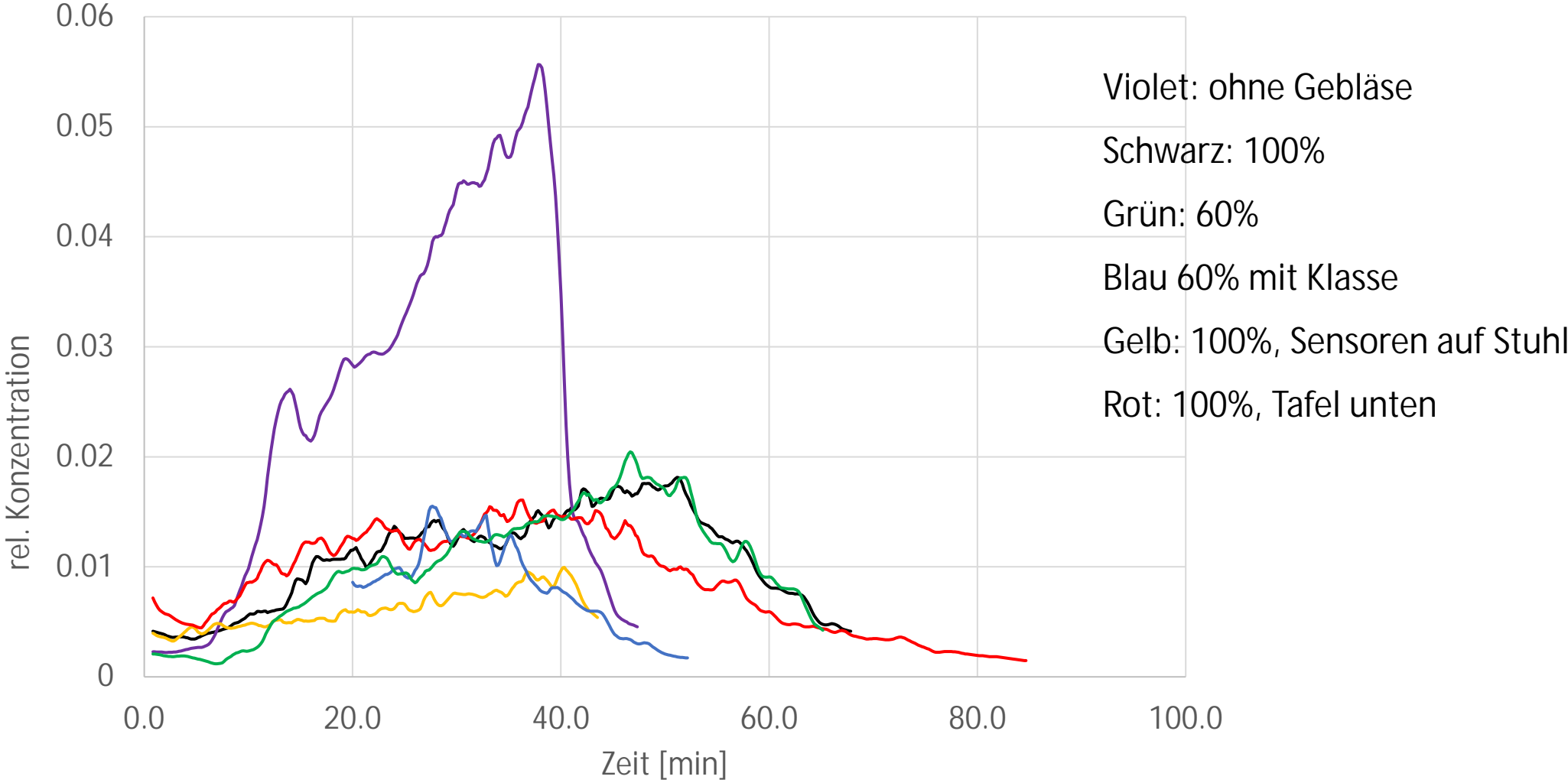

Ambient air filtration

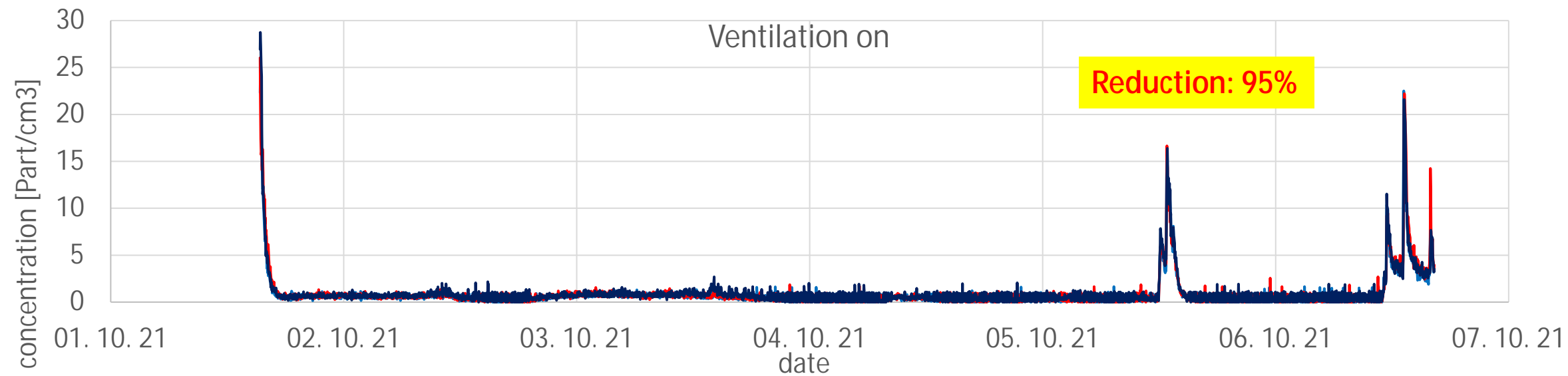
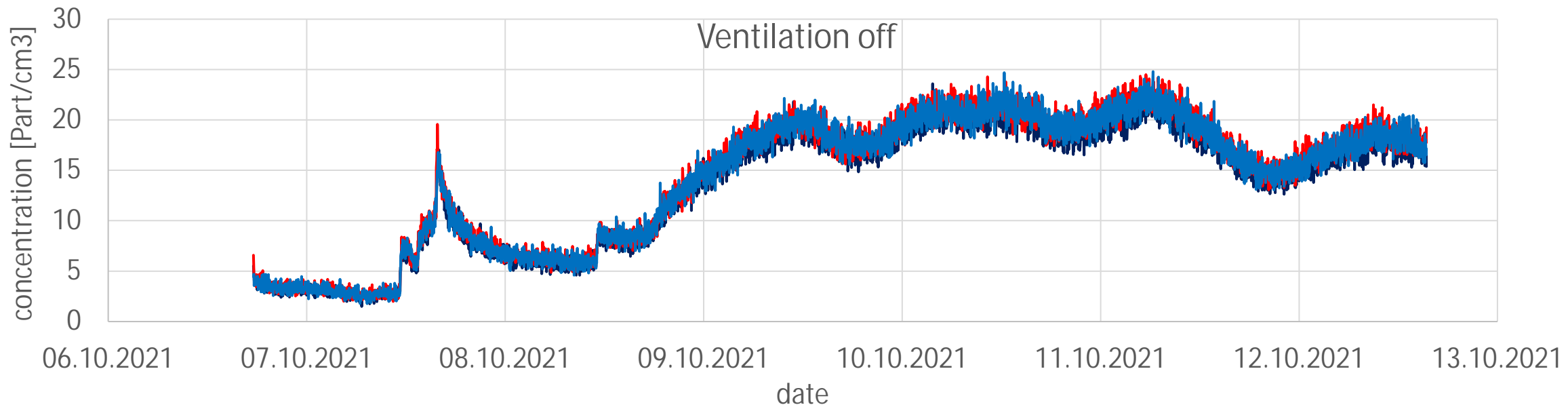



Other applications

- **Elevator cabin: pilot installation at EMCH**
- **Hospital: installation allowing multiple occupancy with infectious patients**

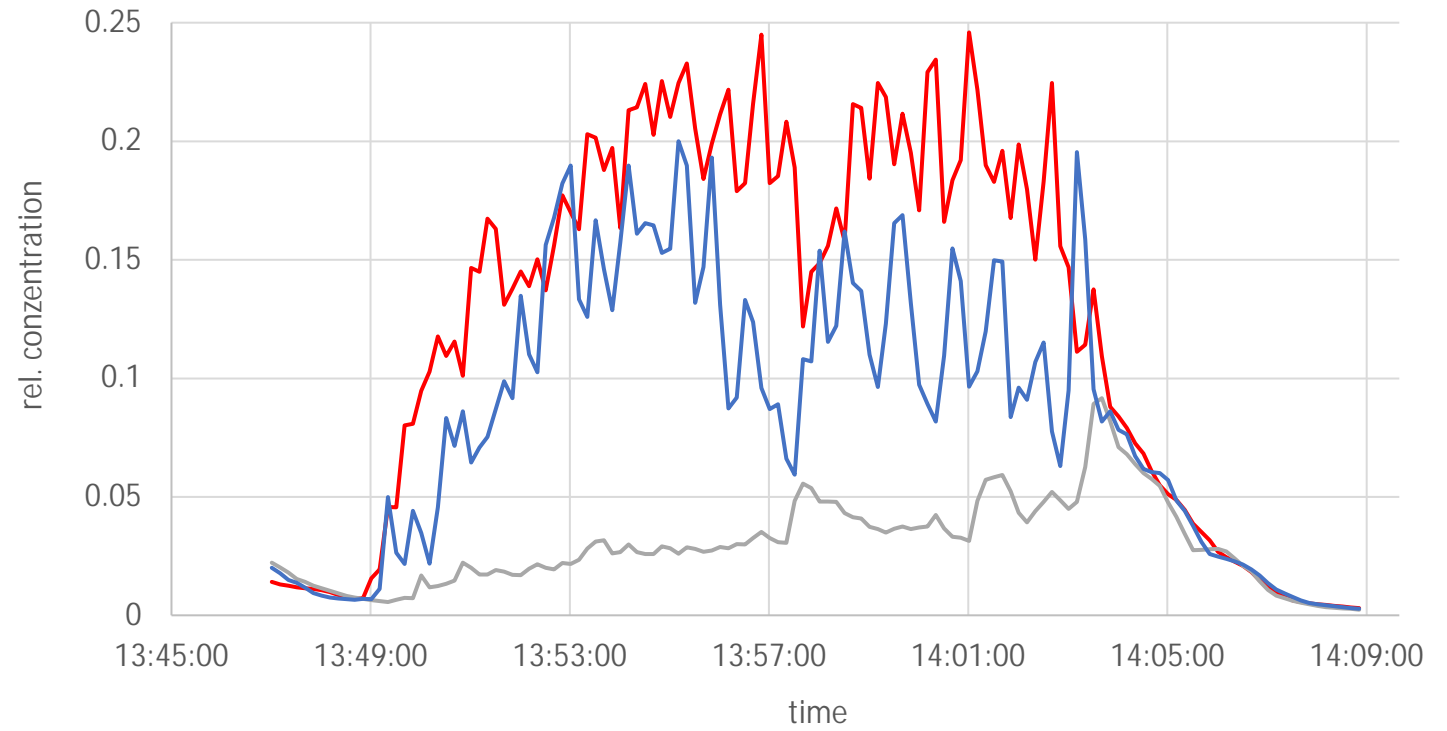
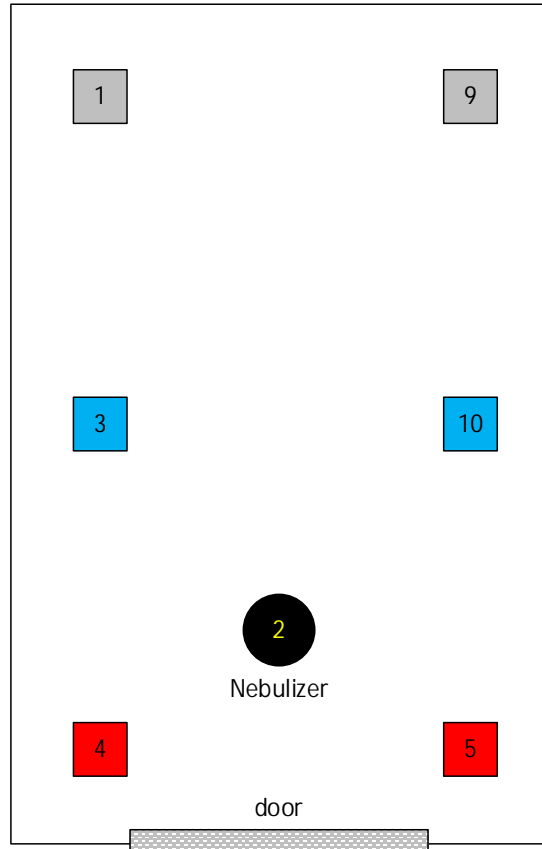



Conclusions

- **Effective filtration possible**
- **Main problem: flow control**
- **Approach: laminar flow, vertically upwards**
- **Important: keep noise level low**
- **Topic also after 'corona' of importance:
other infectious diseases
reduce particulate pollution from outside**



Many thanks

- The Rudolf Steiner School for their great support
- EMCH elevators
- the BAFU environmental technology promotion and the Hightech center Aargau for the financial support



Jan Czerwinski
Thomas Lutz
Andreas Mayer
Jörg Mayer
Rainer Mayer

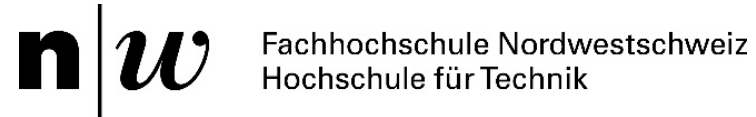

Tobias Rüggeberg
Patrick Specht
Ernest Weingartner



Laetitia Haeni
Céline Loussert-Fonta
Ana Milosevic
Barbara Rothen-Rutishauser



Christian Lämmle